

TECHNICAL
DRAWINGS
ALGARVE

ABOUT THIS DOCUMENT

This interactive PDF offers all the Algarve technical drawings. On the next page you will find the index page with an overview of all available drawings. Click on the titles and you will be redirected to the correct page. When going through the drawings you'll find on the right bottom the Renson logo which leads you back to the index page. Next to that, each drawing has a link to download the PDF or DWG file.

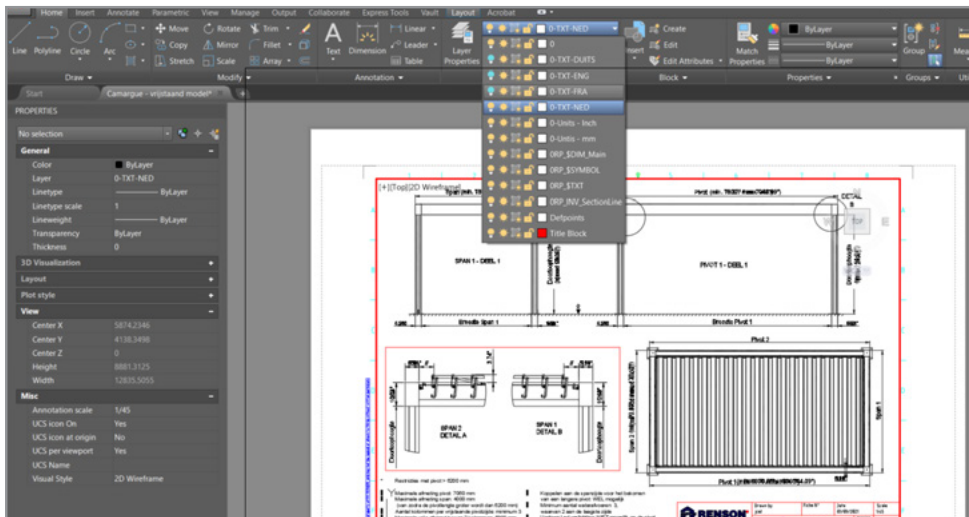
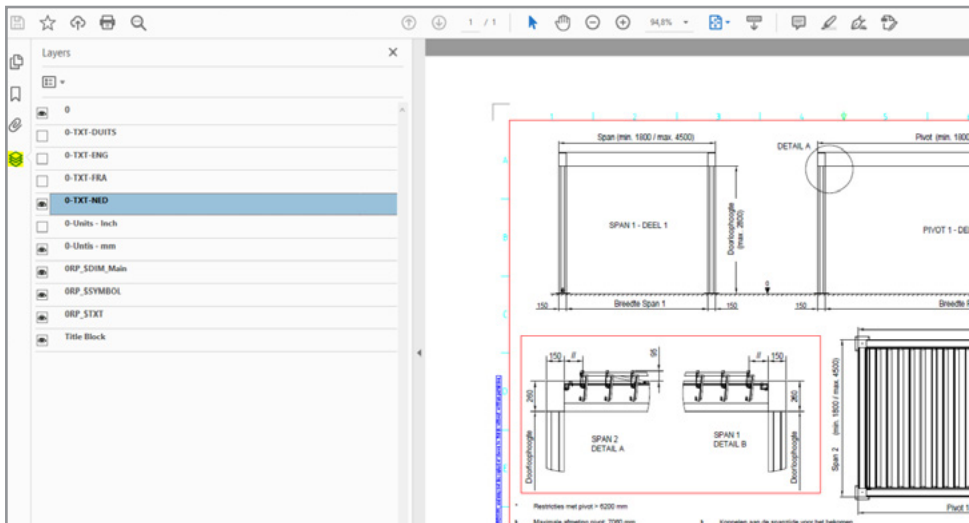

HOW TO TURN ON/OFF LANGUAGES AND DIMENSION LAYERS

- in PDF viewer

When opening the pdf document, notice several layers are standing over each other. Go to the left side of the pdf and click on the tab called 'layers'. A menu will appear with the different language and dimension layers. Turn layers on and off by clicking on the eye-icon next to the name of the layer.

- in Autocad

Go to the 'layout' tab at the topbar. A menu will appear with the different layers. Turn layers on and off by clicking on the lightbulbs next to the name of the layer.

INDEX

Construction Algarve

Freestanding

Freestanding
intermediate column

Façade mounting pivot

Façade mounting span

Single with
intermediate beam

Wall fixation

Visible mounting base

Visible mounting base -
corner

Invisible mounting base

Visible mounting base
reinforced

Visible mounting base
reinforced - corner

Invisible mounting base
reinforced

Water drainage

Accessories Algarve

Stand alone -
fixscreen at pivot side

Stand alone -
fixscreen at span side

Wall at span side -
fixscreen at pivot side

Wall at pivot side -
fixscreen at span side

Glass wall - 3 rails

Glass wall - 4 rails

Glass wall - 5 rails

Glass wall - fixation at wall

Linius wall - single sided

Linius wall - double sided

Linius wall - double sided
as railing

Outdoor loggia -
2 sliding panels

Outdoor loggia -
4 sliding panels

Curtain

Algarve - FREESTANDING

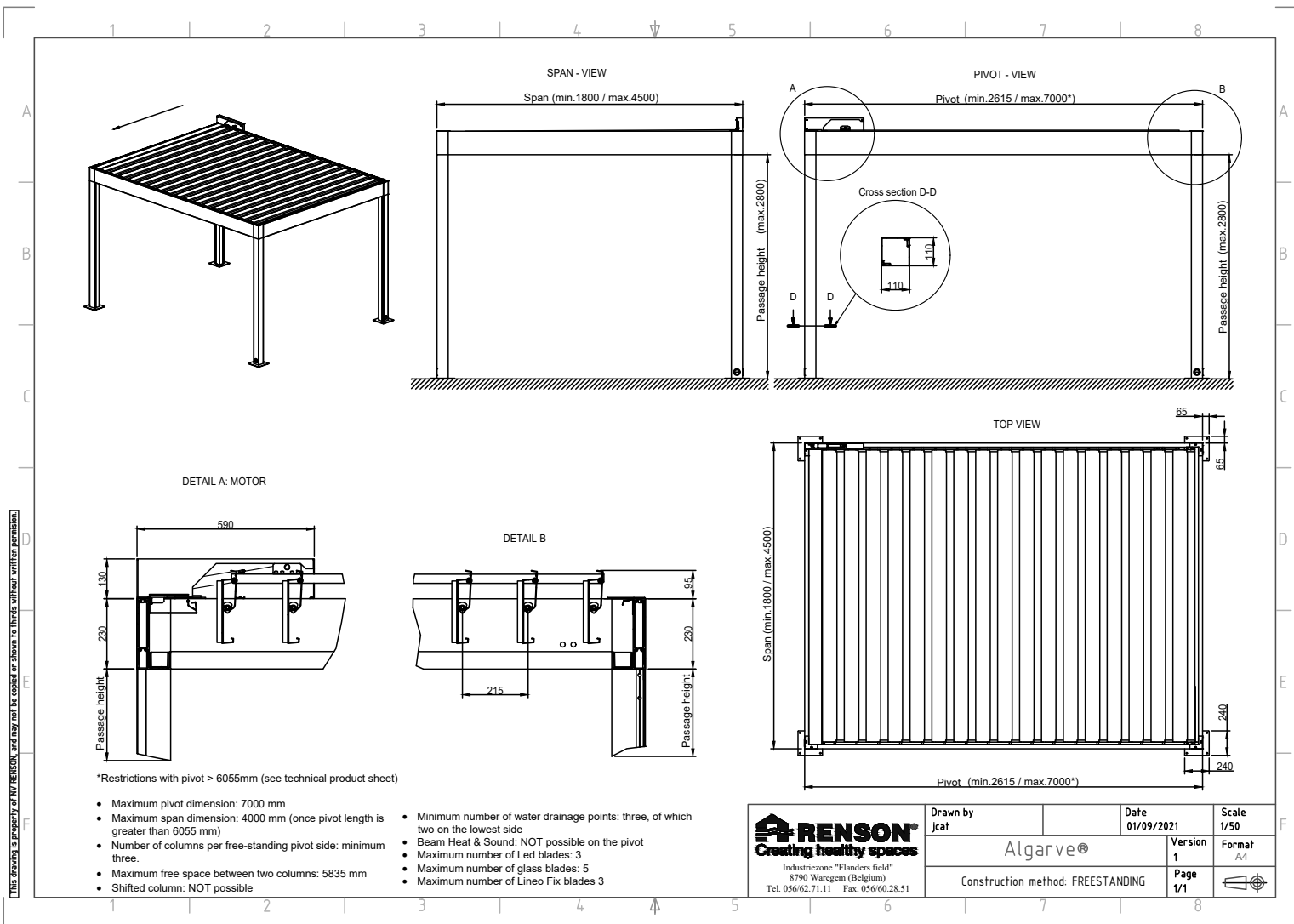

Download this drawing DWG

Download this drawing PDF

Algarve - FREESTANDING INTERMEDIATE COLUMN

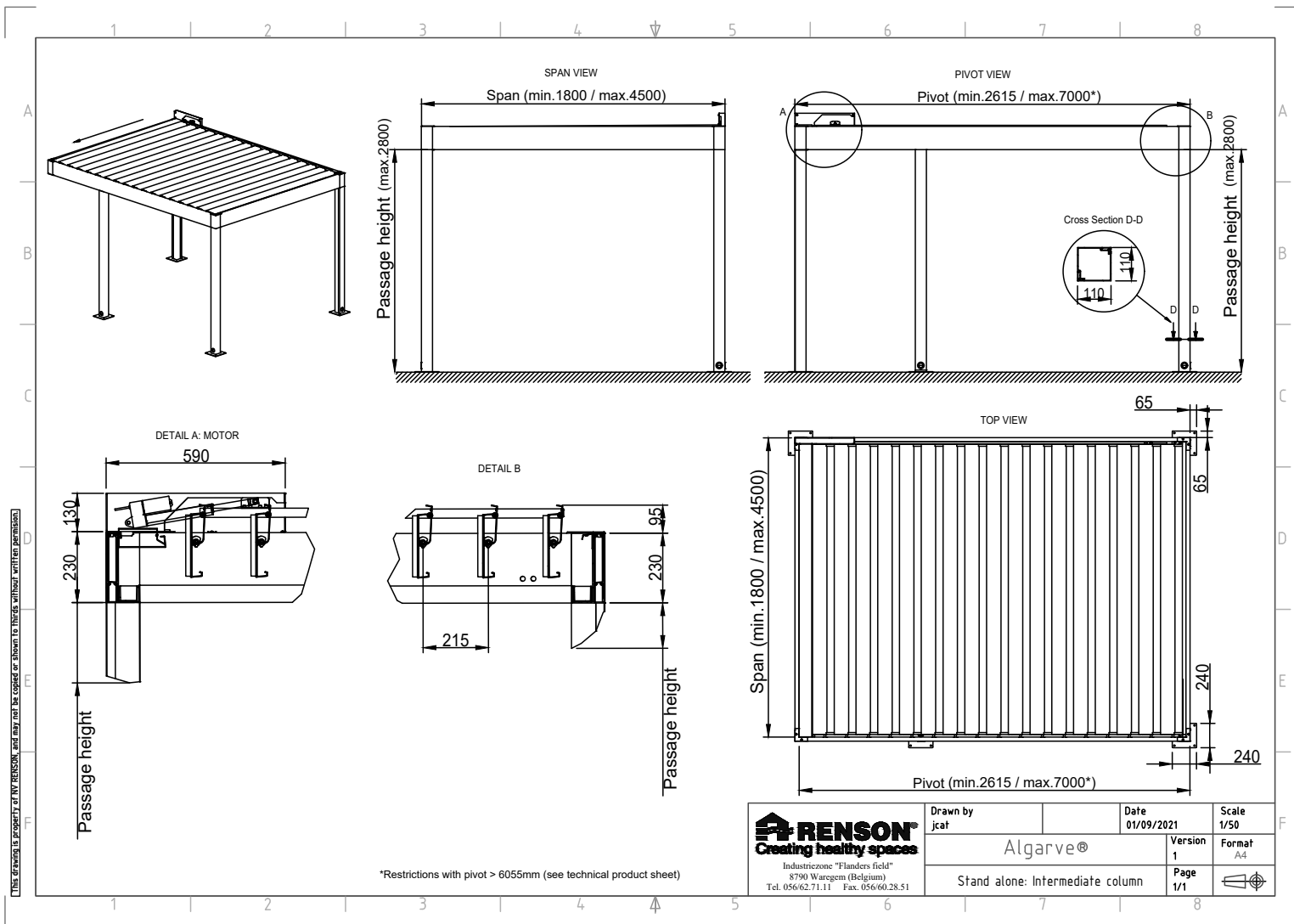

Download this drawing DWG

Download this drawing PDF

Algarve - FAÇADE MOUNTING PIVOT

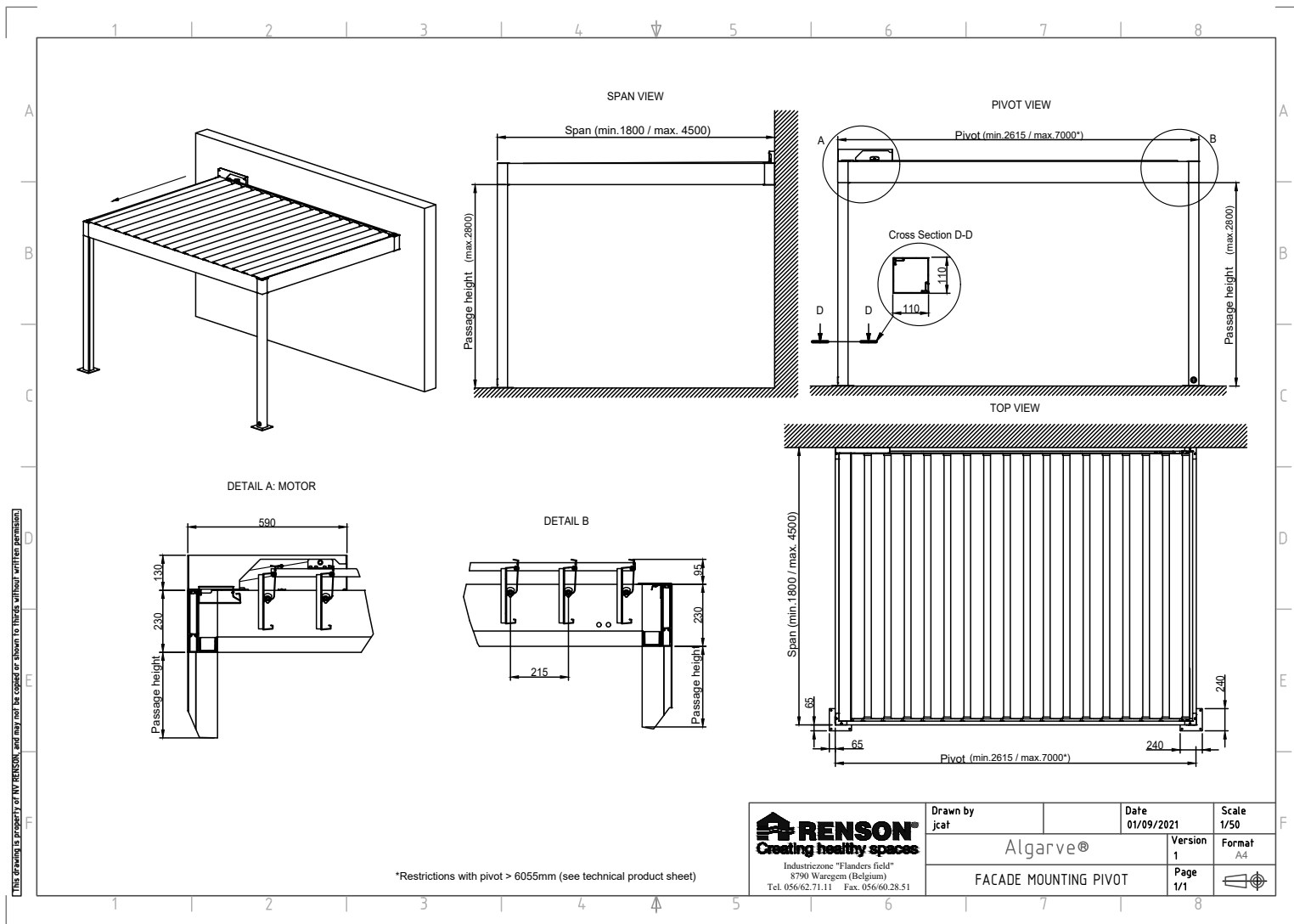

Download this drawing DWG

Download this drawing PDF

Algarve - FAÇADE MOUNTING SPAN

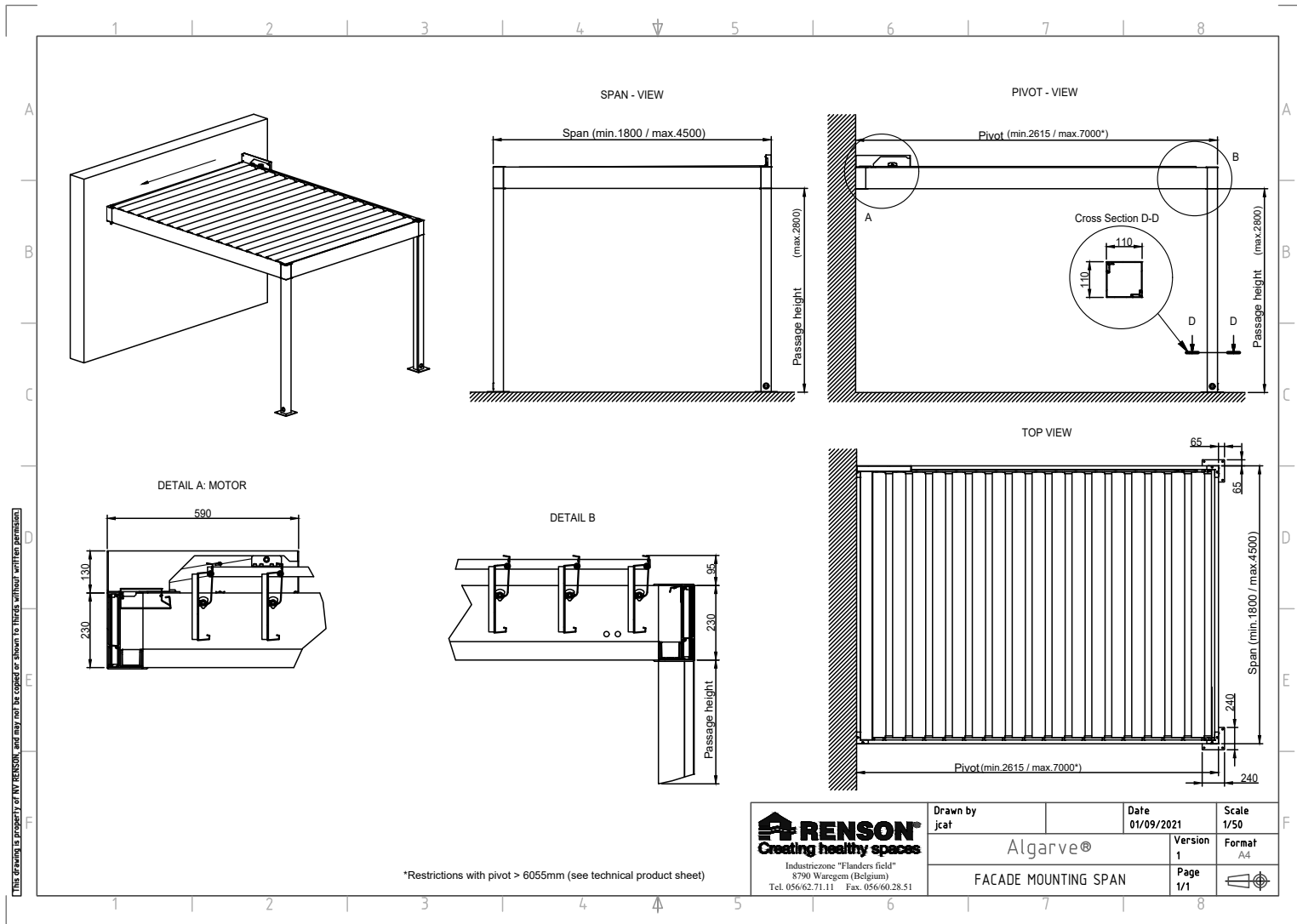

Download this drawing DWG

Download this drawing PDF

Algarve - SINGLE WITH INTERMEDIATE BEAM

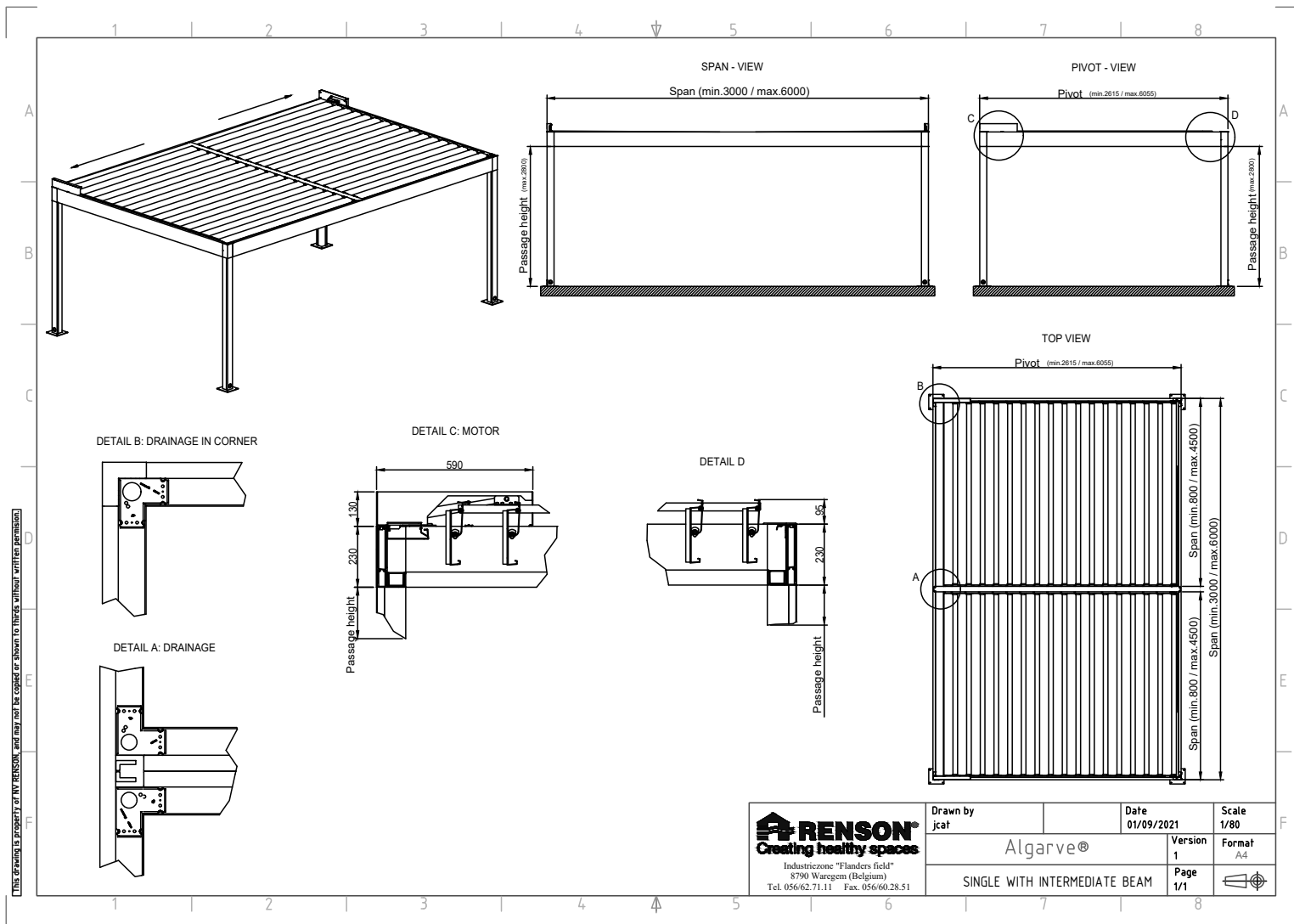

Download this drawing DWG

Download this drawing PDF

Algarve - WALL FIXATION

Position of the mounting holes in the wall

SPAN 1

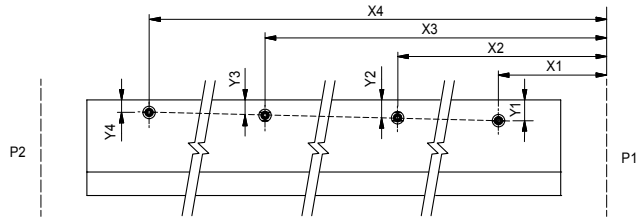

SPAN 2

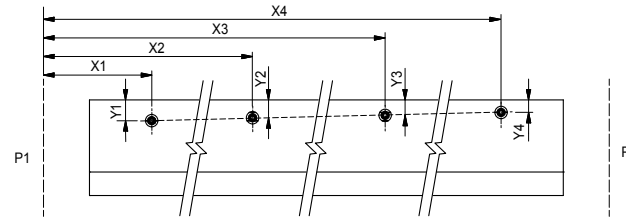

PIVOT 1

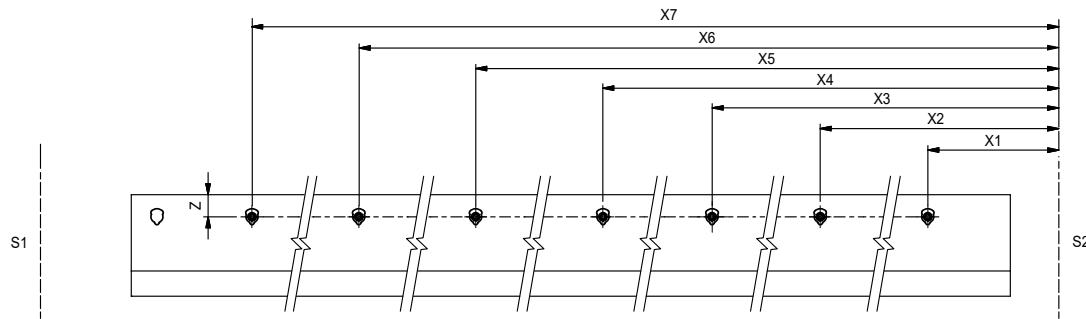

PIVOT 2

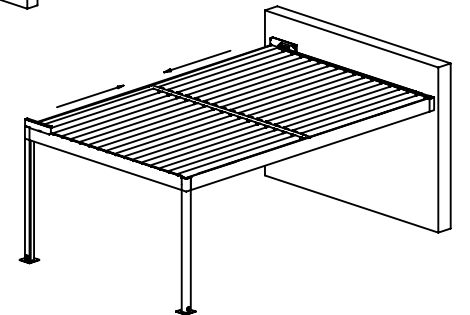
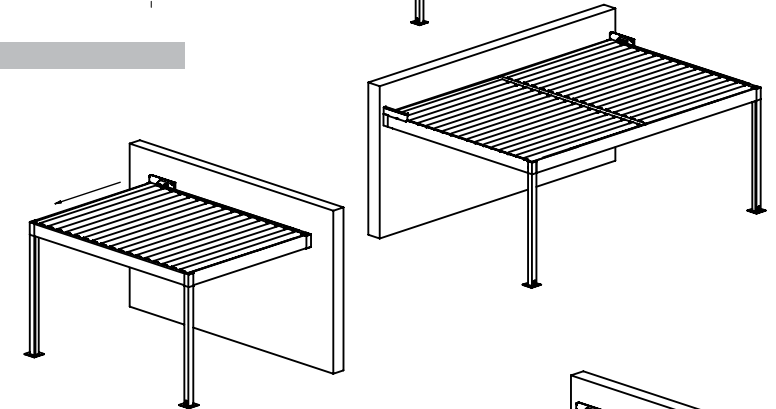
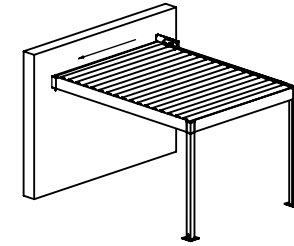
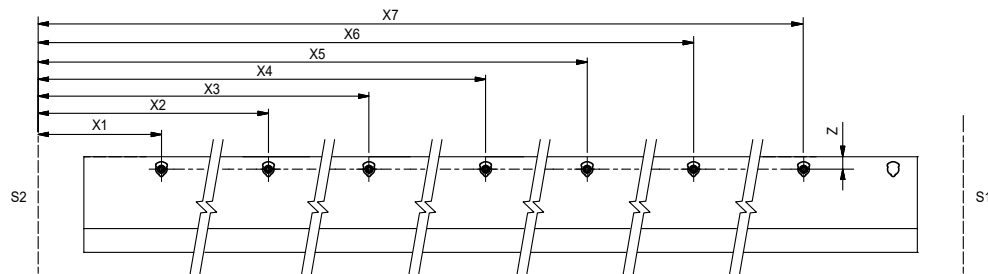

[Download calculation tool](#)

Algarve - VISIBLE MOUNTING BASE

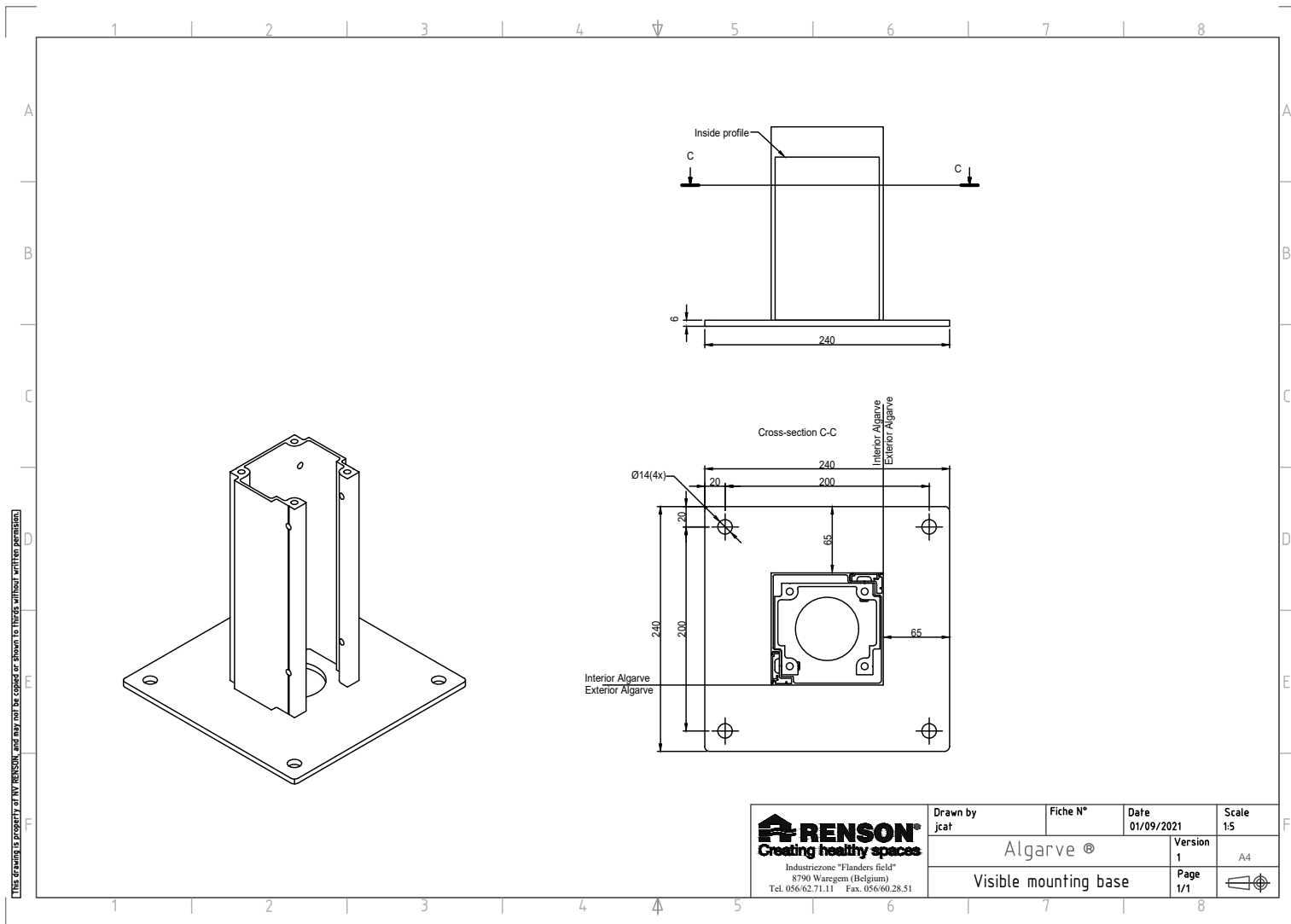

RENSON Creating healthy spaces Industriezone "Flanders field" 8790 Waregem (Belgium) Tel. 056/62.71.11 Fax. 056/60.28.51	Drawn by jcat	Fiche N°	Date 01/09/2021	Scale 1:5
	Algarve ®			Version 1
	Visible mounting base			Page 1/1

Download this drawing DWG

Download this drawing PDF

Algarve - VISIBLE MOUNTING BASE CORNER

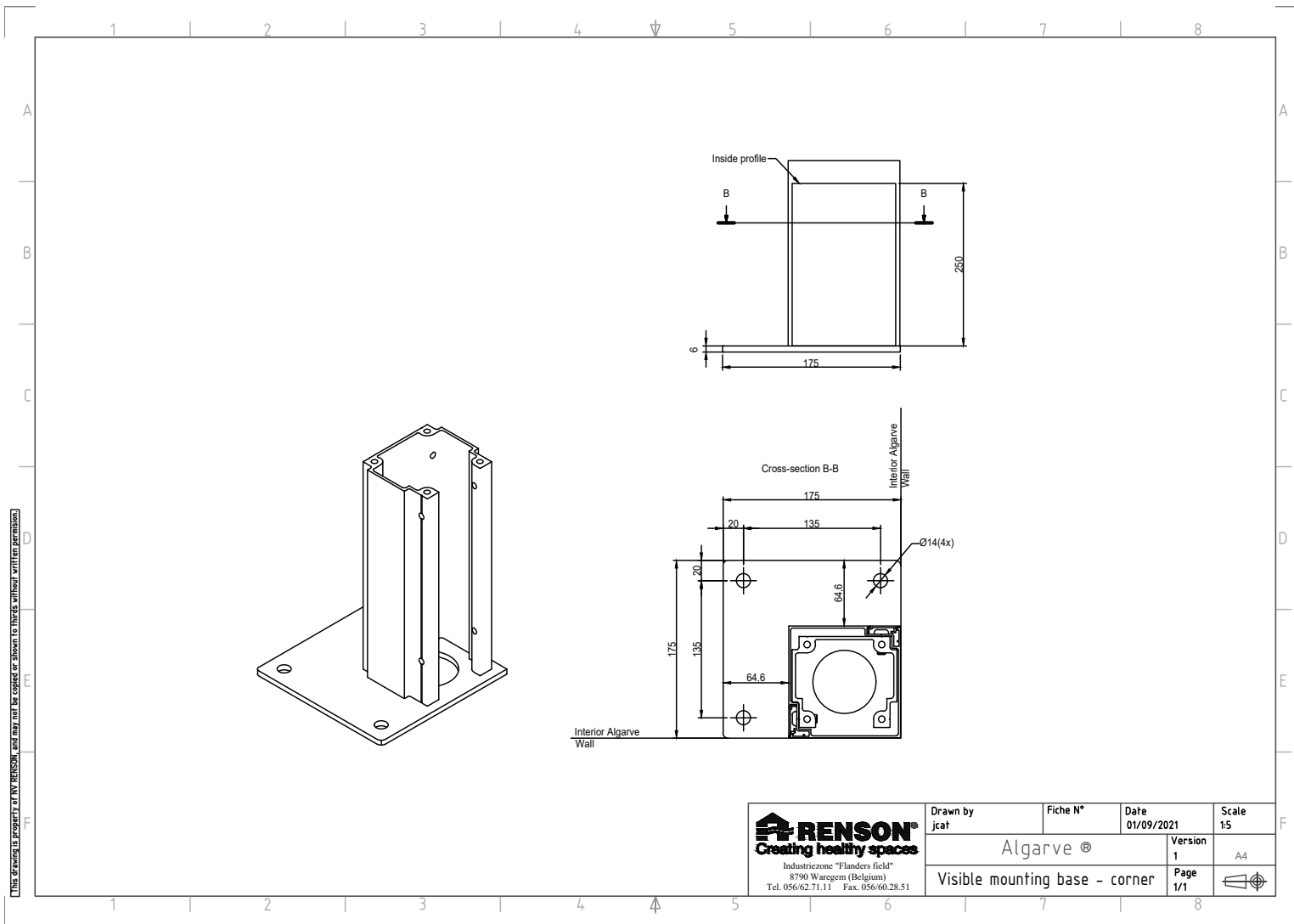

This drawing is property of NV RENSON, and may not be copied or shown to third parties without written permission.

 <p>Industriezone "Flanders field" 8790 Waregem (Belgium) Tel. 056/62.71.11 Fax. 056/60.28.51</p>	Drawn by jcat	Fiche N°	Date 01/09/2021	Scale 1:5
	Algarve ®			Version 1
	Visible mounting base - corner			Page 1/1

Download this drawing DWG

Download this drawing PDF

Algarve - INVISIBLE MOUNTING BASE

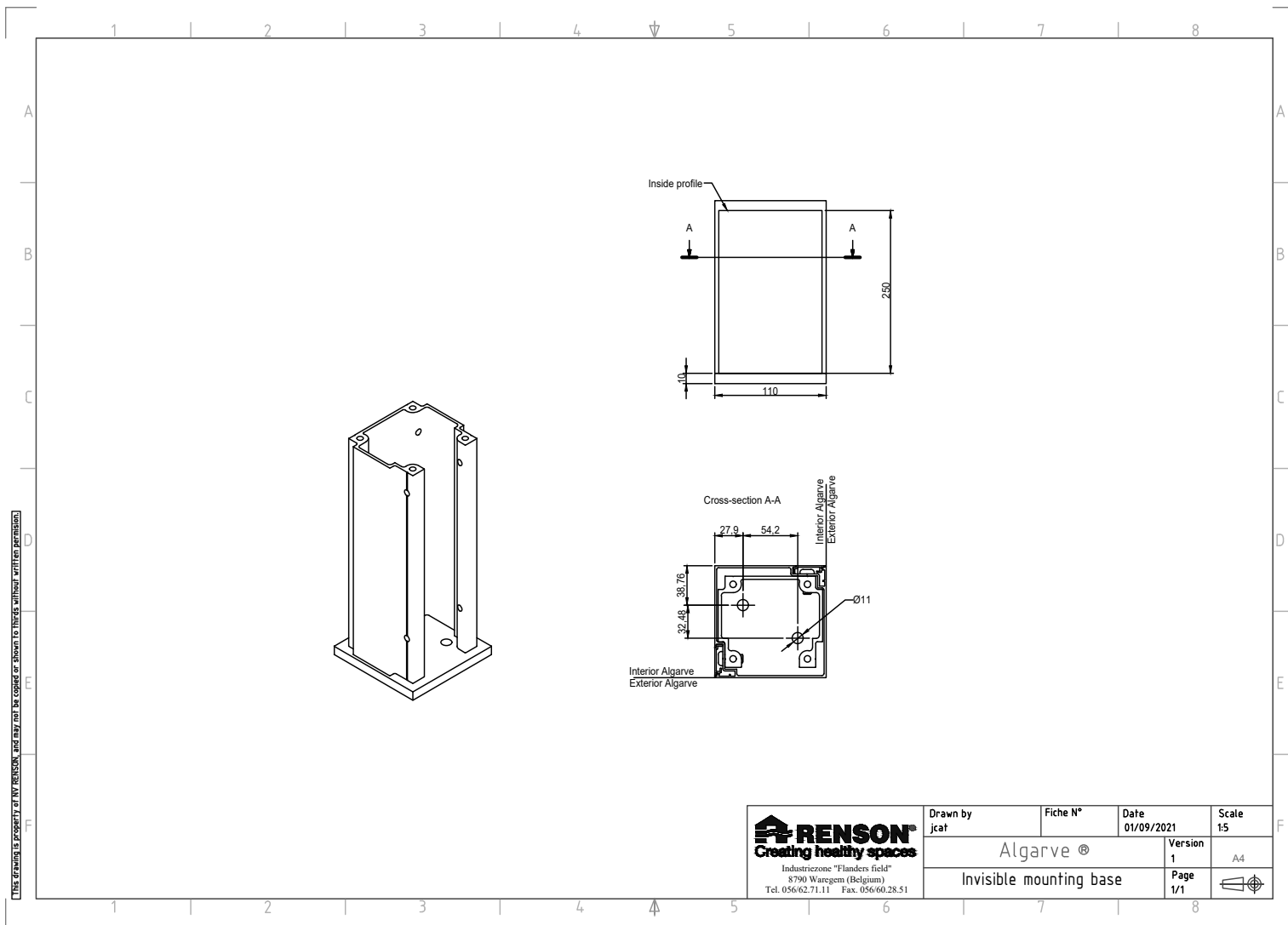

Download this drawing DWG

Download this drawing PDF

Algarve - VISIBLE MOUNTING BASE REINFORCED

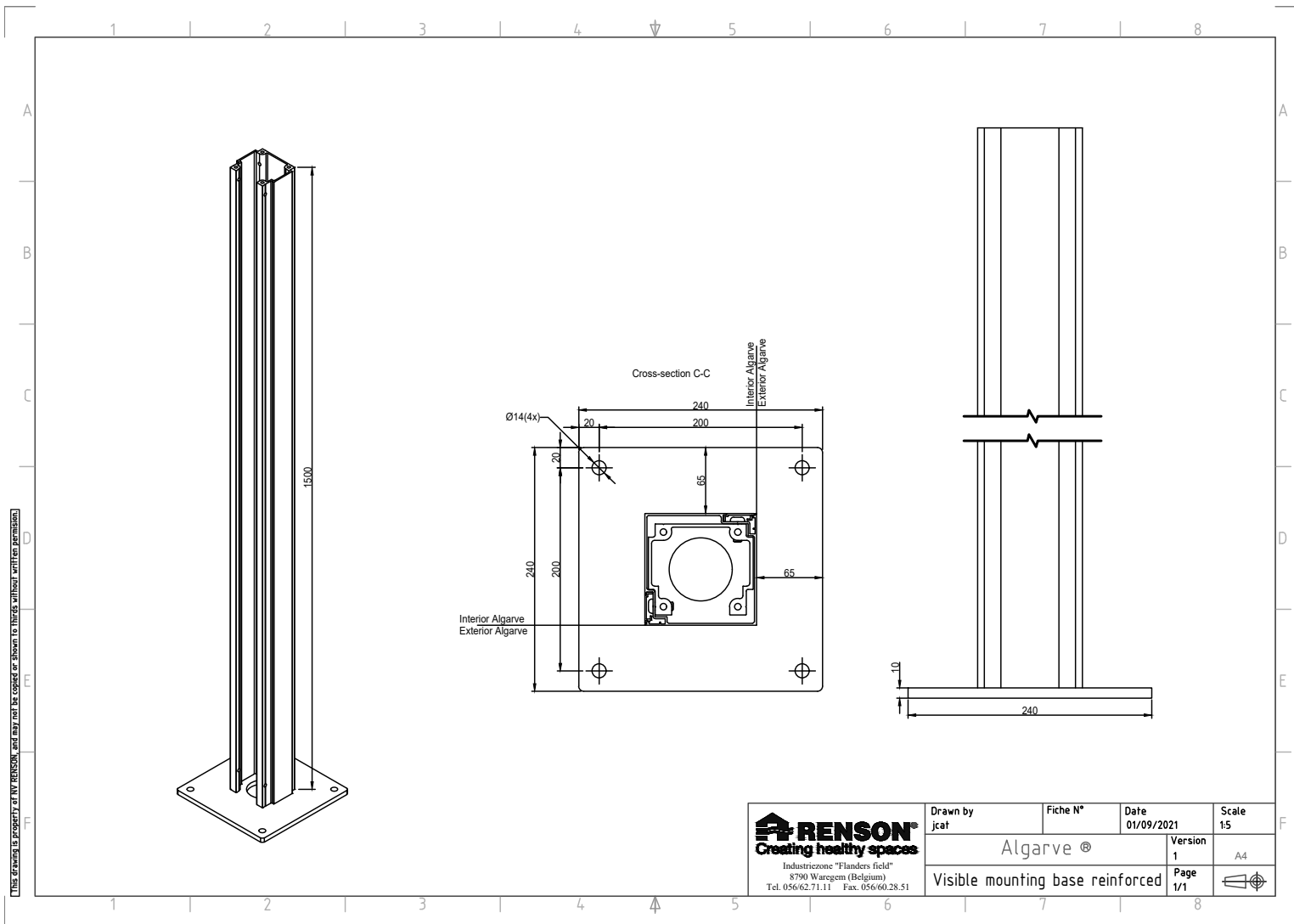

Download this drawing DWG

Download this drawing PDF

Algarve - VISIBLE MOUNTING BASE REINFORCED - CORNER

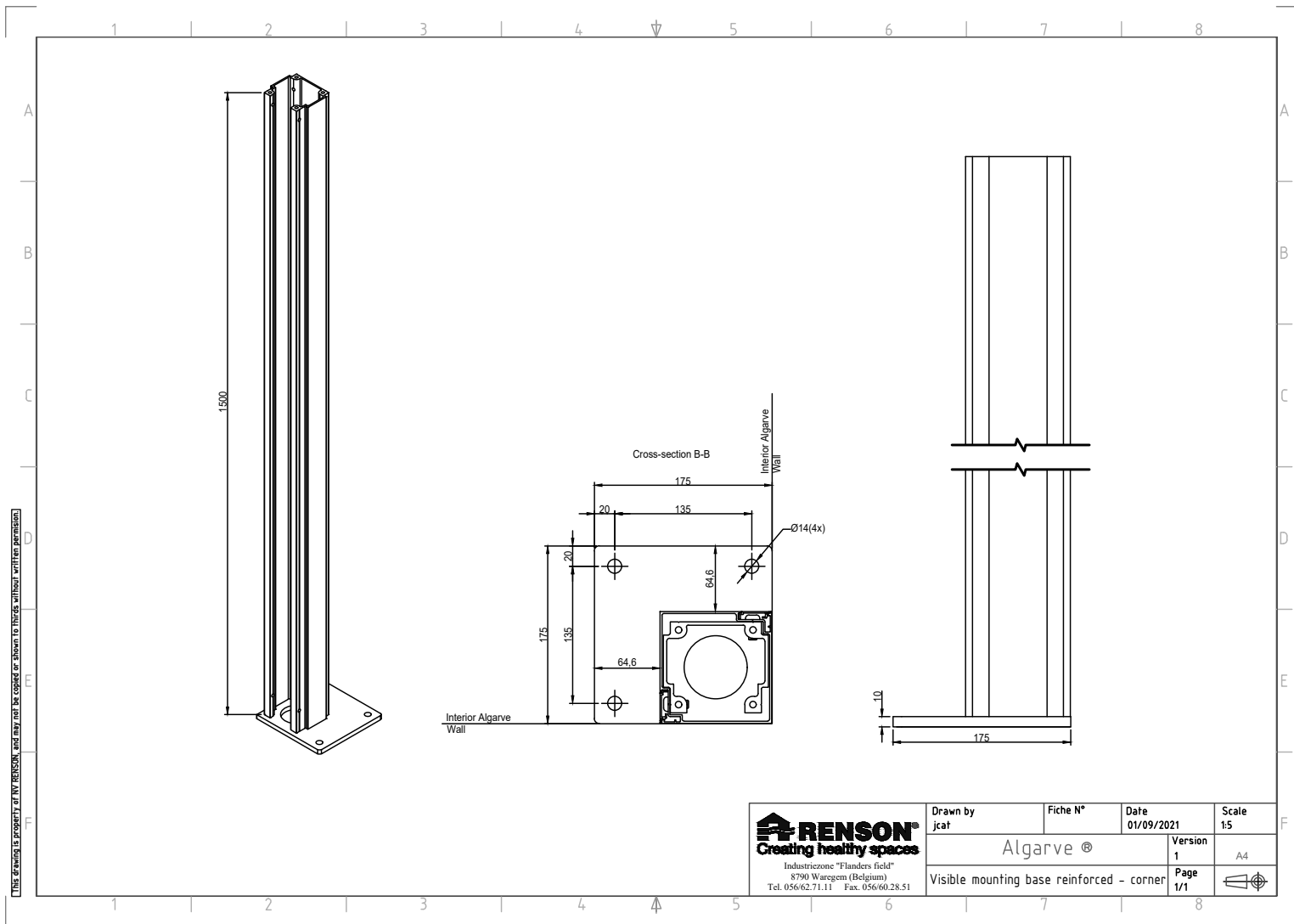



Download this drawing DWG

Download this drawing PDF

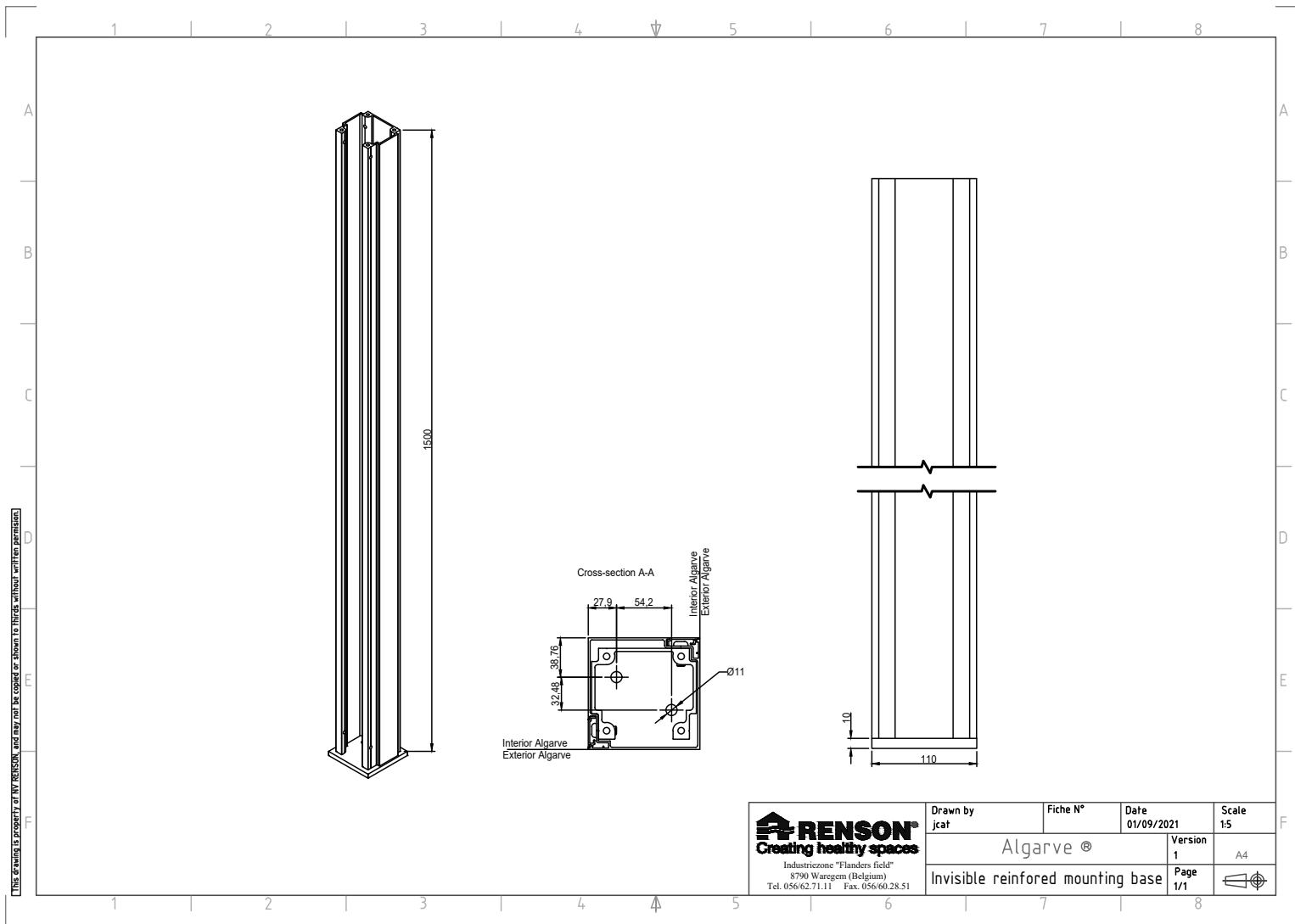
Algarve - INVISIBLE MOUNTING BASE REINFORCED



 RENSON Creating healthy spaces Industriezone "Flanders field" 8790 Waregem (Belgium) Tel. 056/62.71.11 Fax. 056/60.28.51	Drawn by jcat	Fiche N°	Date 01/09/2021	Scale 1:5	
	Algarve ®			Version 1	A4
Invisible reinforced mounting base				Page 1/1	

Download this drawing DWG

Download this drawing PDF

Algarve - WATER DRAINAGE

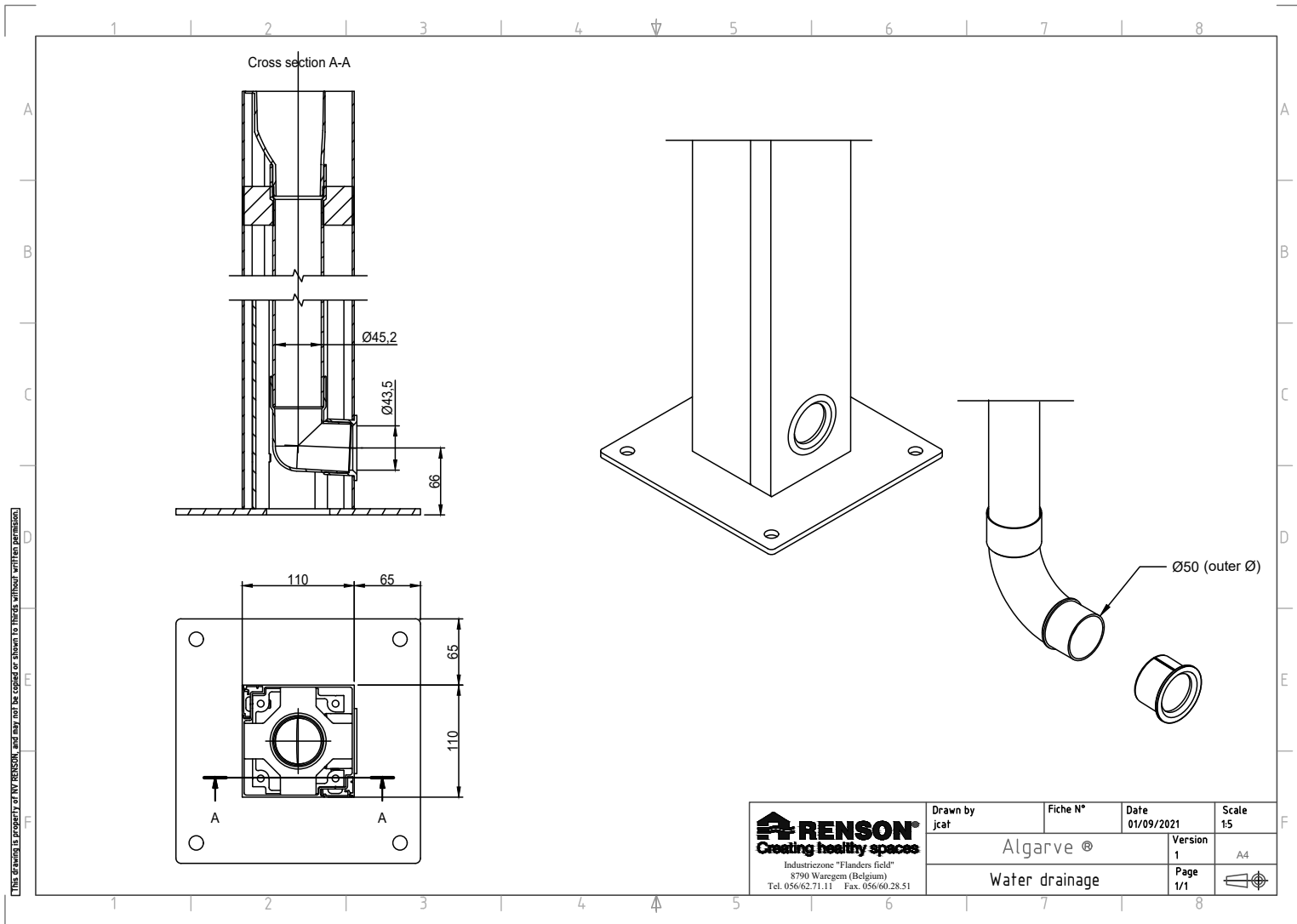

Download this drawing DWG

Download this drawing PDF

Algarve - STAND ALONE - FIXSCREEN AT SPAN SIDE

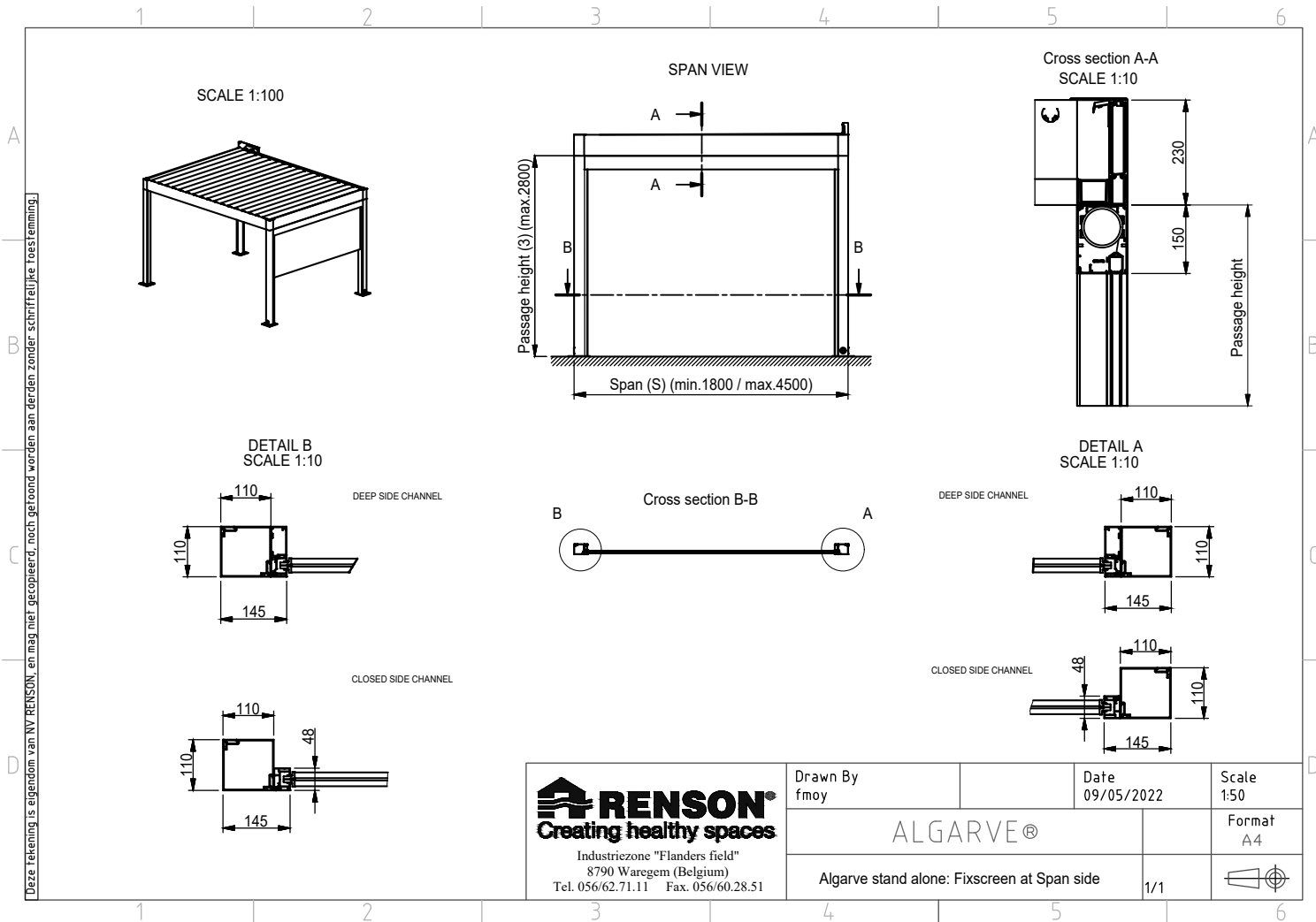

Download this drawing DWG

Download this drawing PDF

Algarve - WALL AT SPAN SIDE - FIXSCREEN AT PIVOT SIDE

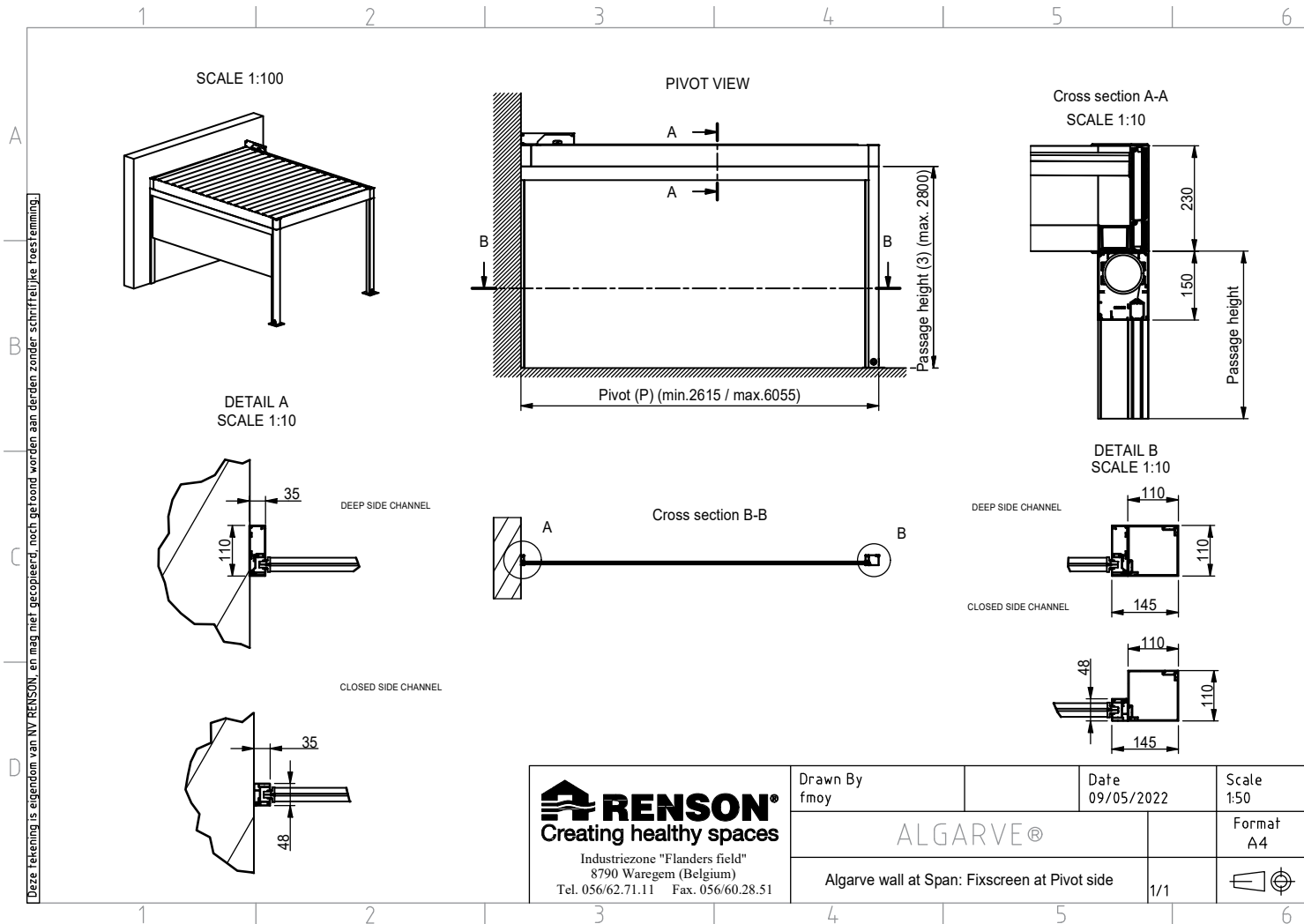

Download this drawing DWG

Download this drawing PDF

Algarve - GLASS WALL - 3 RAILS

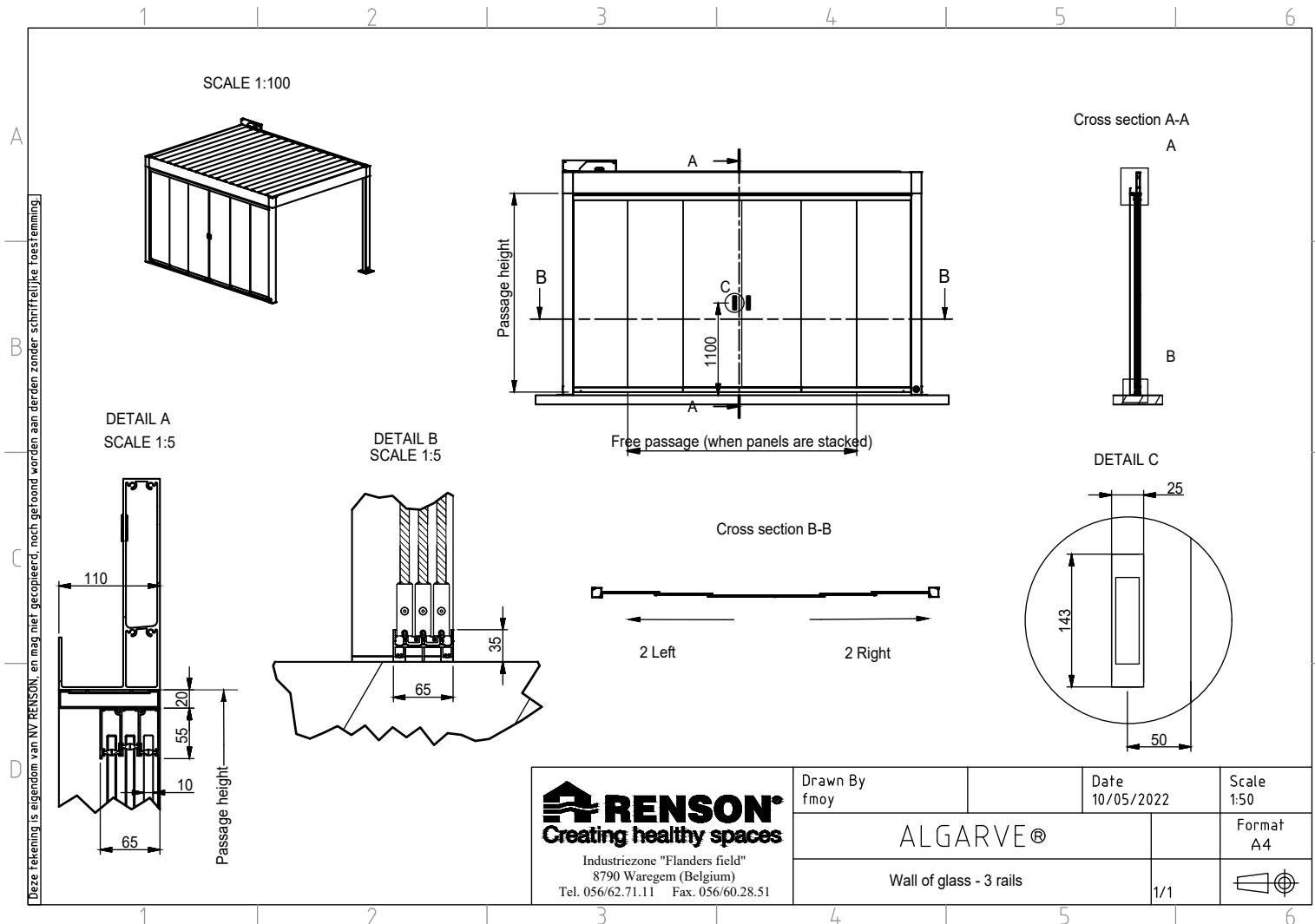

Deze tekening is eigendom van NV RENSON, en mag niet gecopieerd, noch getoond worden aan derden zonder schriftelijke toestemming.

RENSON
Creating healthy spaces

Industriezone "Flanders field"
8790 Waregem (Belgium)
Tel. 056/62.71.11 Fax. 056/60.28.51

Drawn By fmoy	Date 10/05/2022	Scale 1:50
ALGARVE®		Format A4
Wall of glass - 3 rails		1/1

Download this drawing DWG

Download this drawing PDF

Algarve - GLASS WALL - 4 RAILS

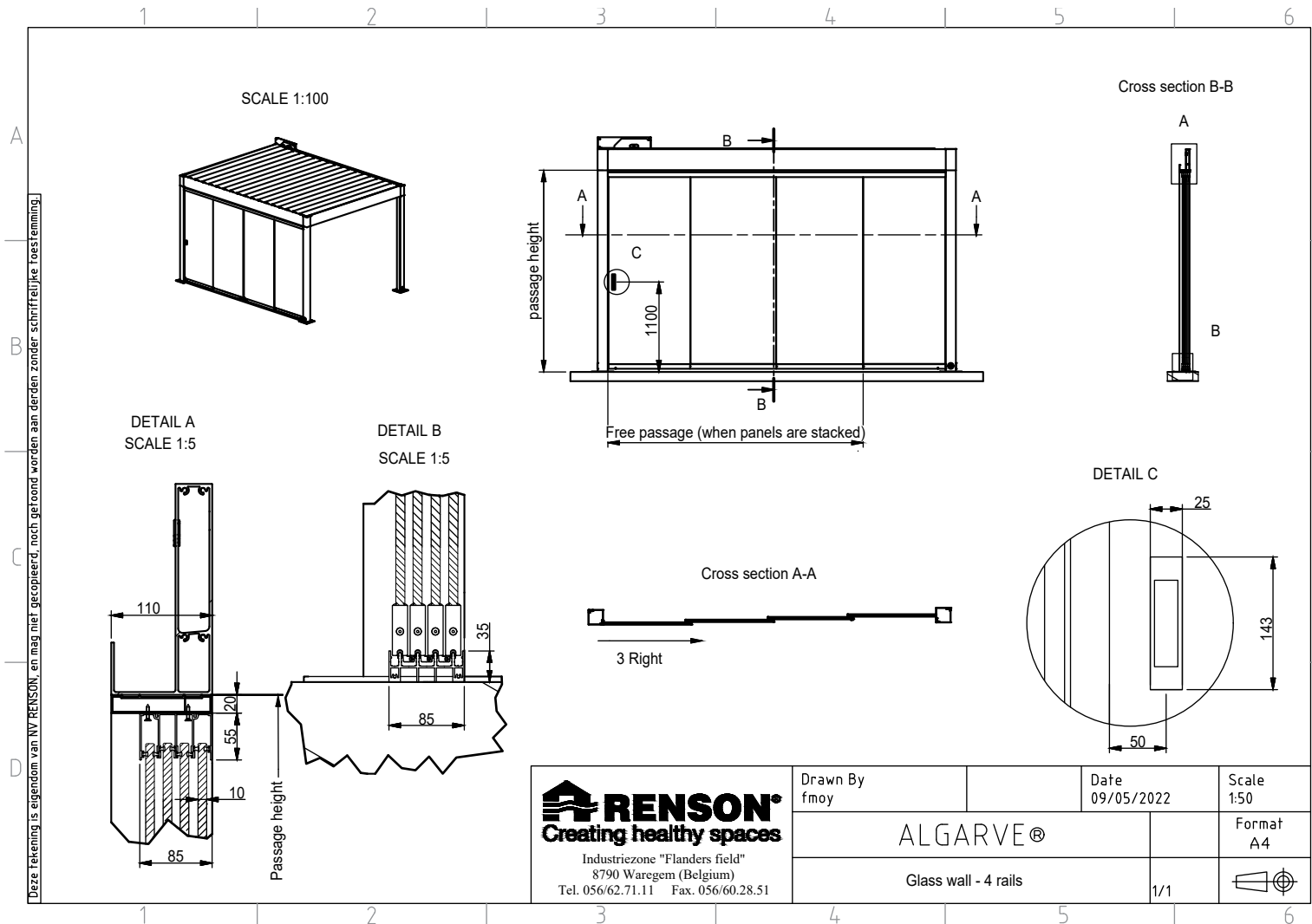

Deze tekening is eigendom van NV RENSON, en mag niet gecopieerd, noch getoond worden aan derden zonder schriftelijke toestemming.

<p>RENSON® Creating healthy spaces</p> <p>Industriezone "Flanders field" 8790 Waregem (Belgium) Tel. 056/62.71.11 Fax. 056/60.28.51</p>	Drawn By fmoy	Date 09/05/2022	Scale 1:50
	ALGARVE®		Format A4
	Glass wall - 4 rails	1/1	

Download this drawing DWG

Download this drawing PDF

Algarve - GLASS WALL - 5 RAILS

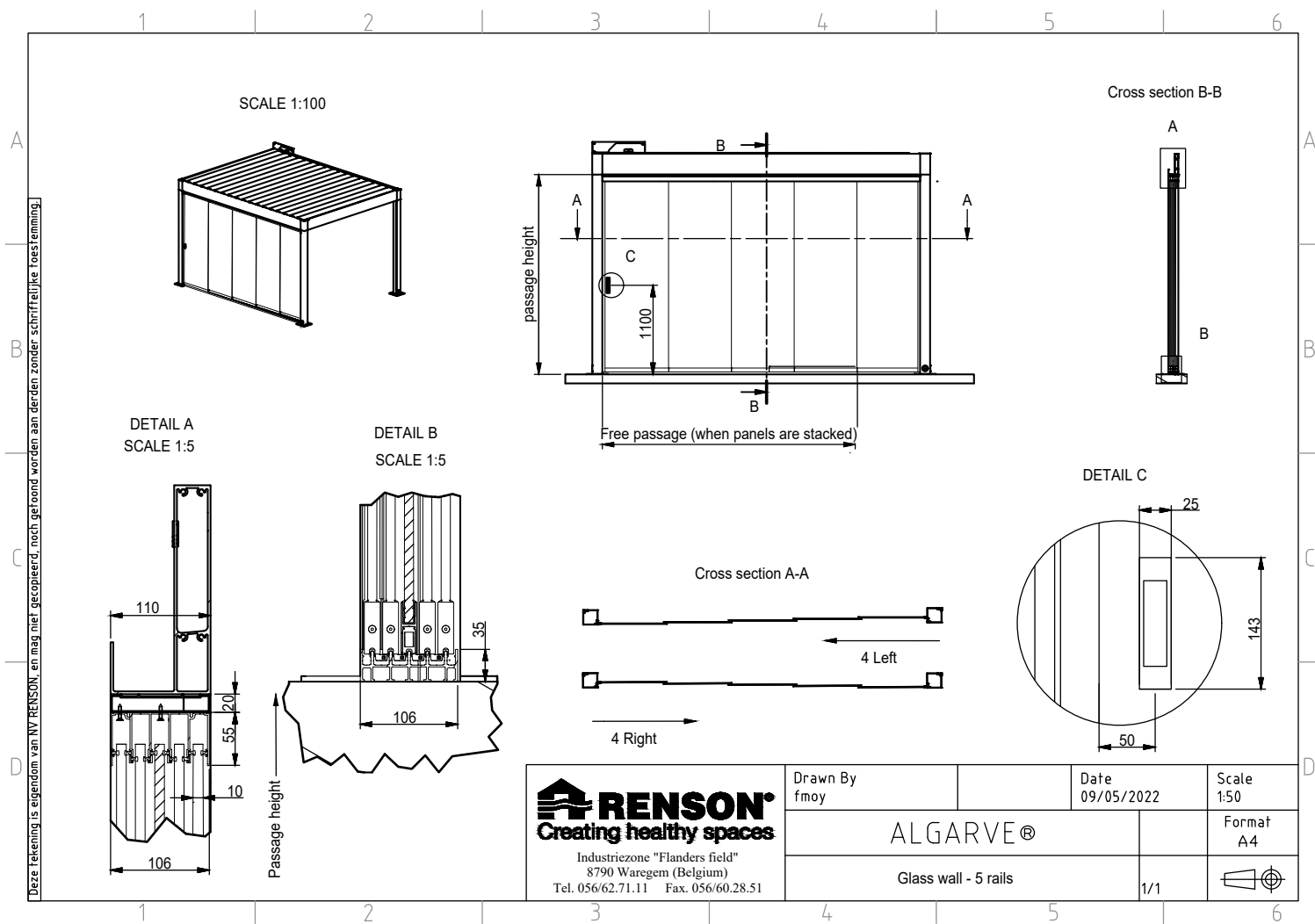

Download this drawing DWG

Download this drawing PDF

Algarve - GLASS WALL - FIXATION AT WALL

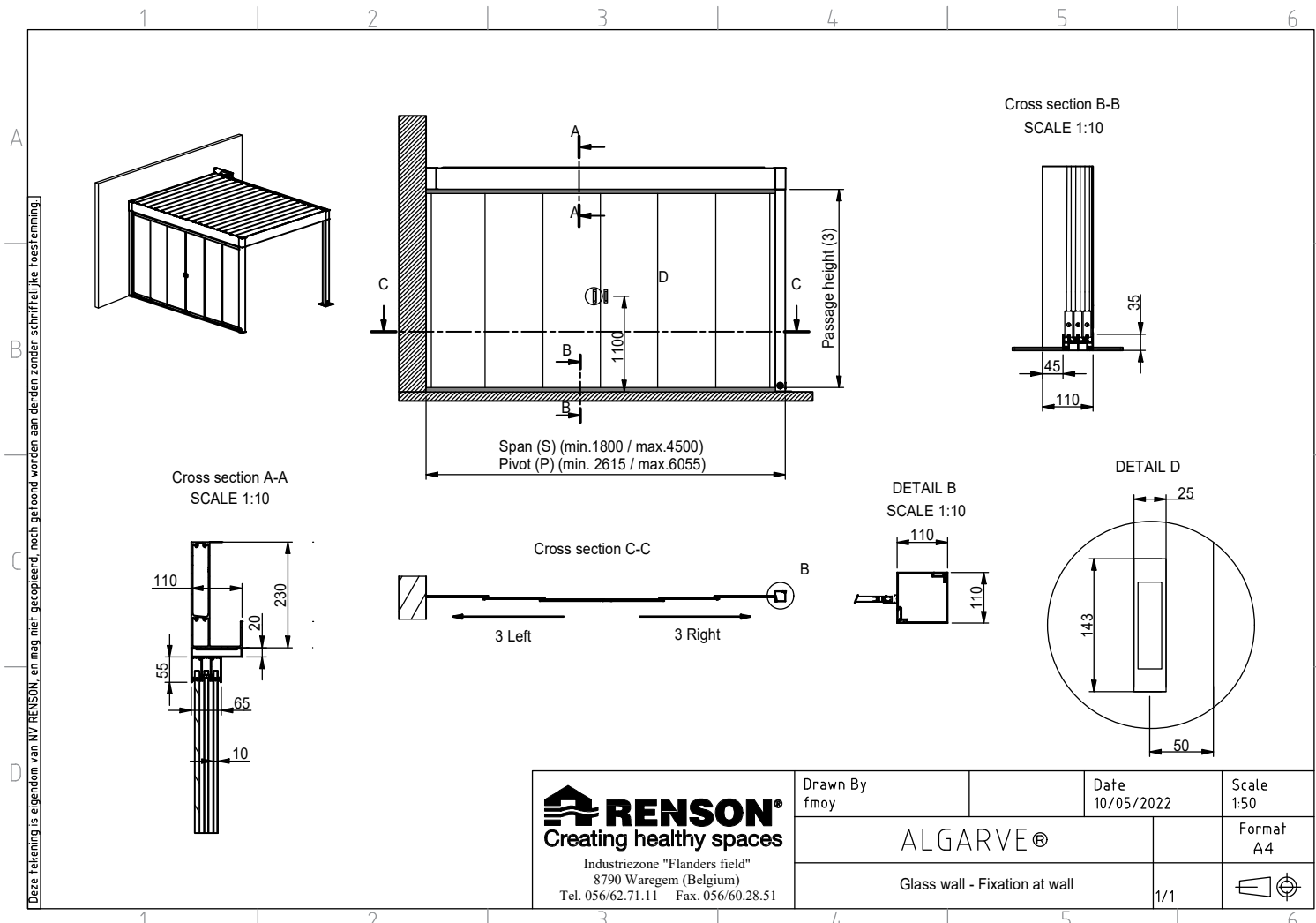

Download this drawing DWG

Download this drawing PDF

Algarve - LINIUS WALL - SINGLE SIDED

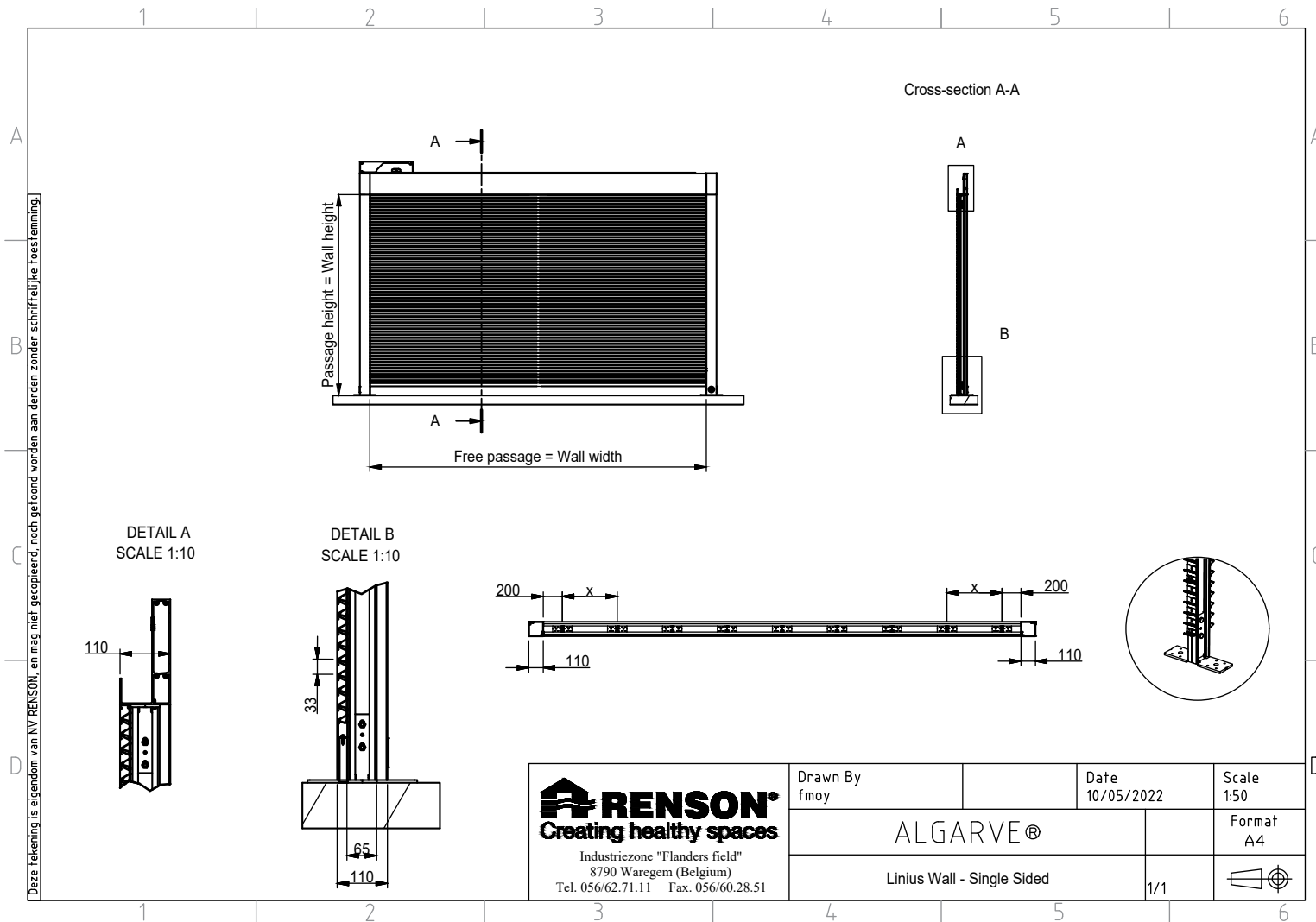

Download this drawing DWG

Download this drawing PDF

Algarve - LINIUS WALL - DOUBLE SIDED

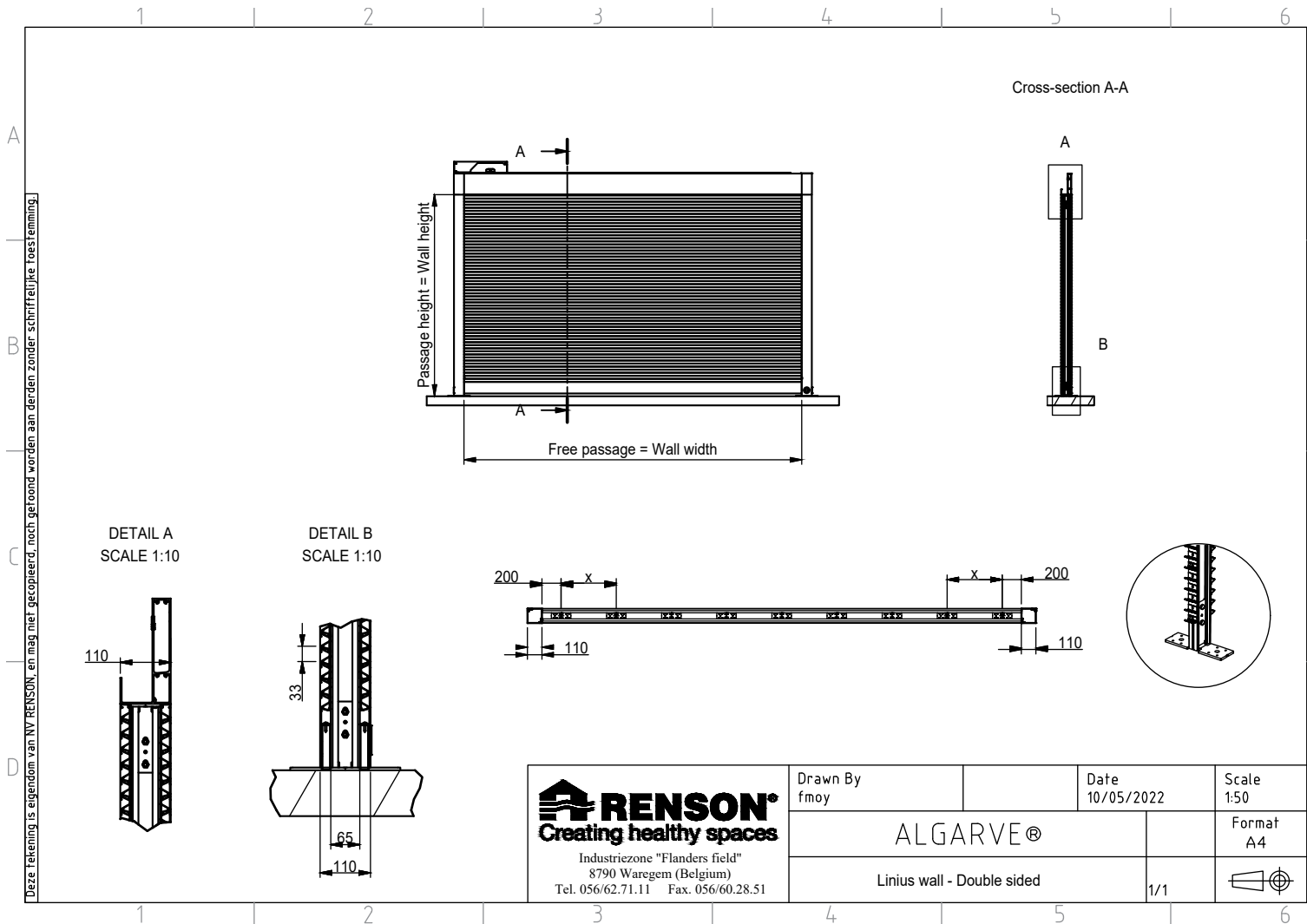

Download this drawing DWG

Download this drawing PDF

Algarve - LINIUS WALL - DOUBLE SIDED AS RAILING

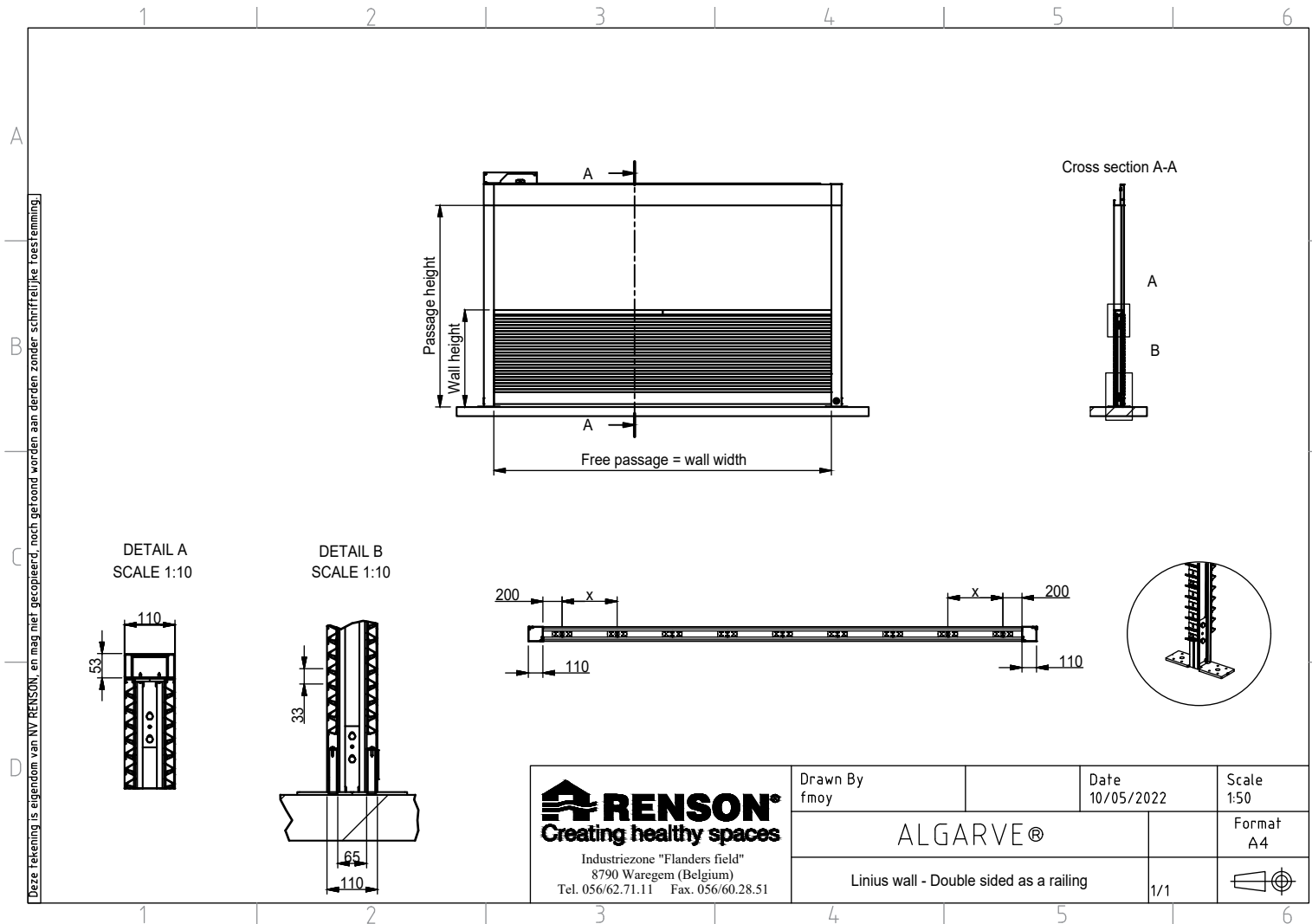

Download this drawing DWG

Download this drawing PDF

Algarve - OUTDOOR LOGGIA - 2 SLIDING PANELS

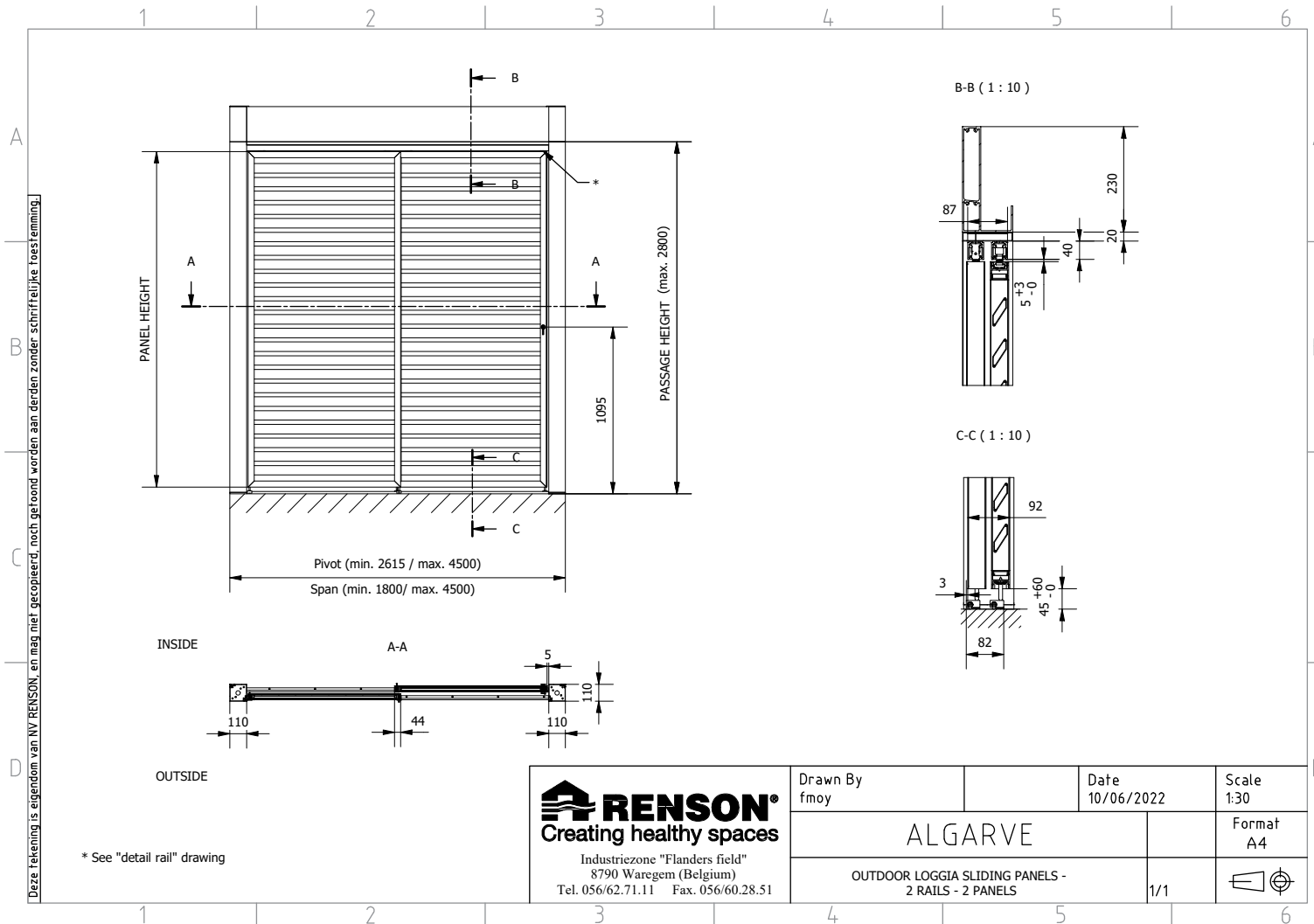

Download this drawing DWG

Download this drawing PDF

Algarve - CURTAIN

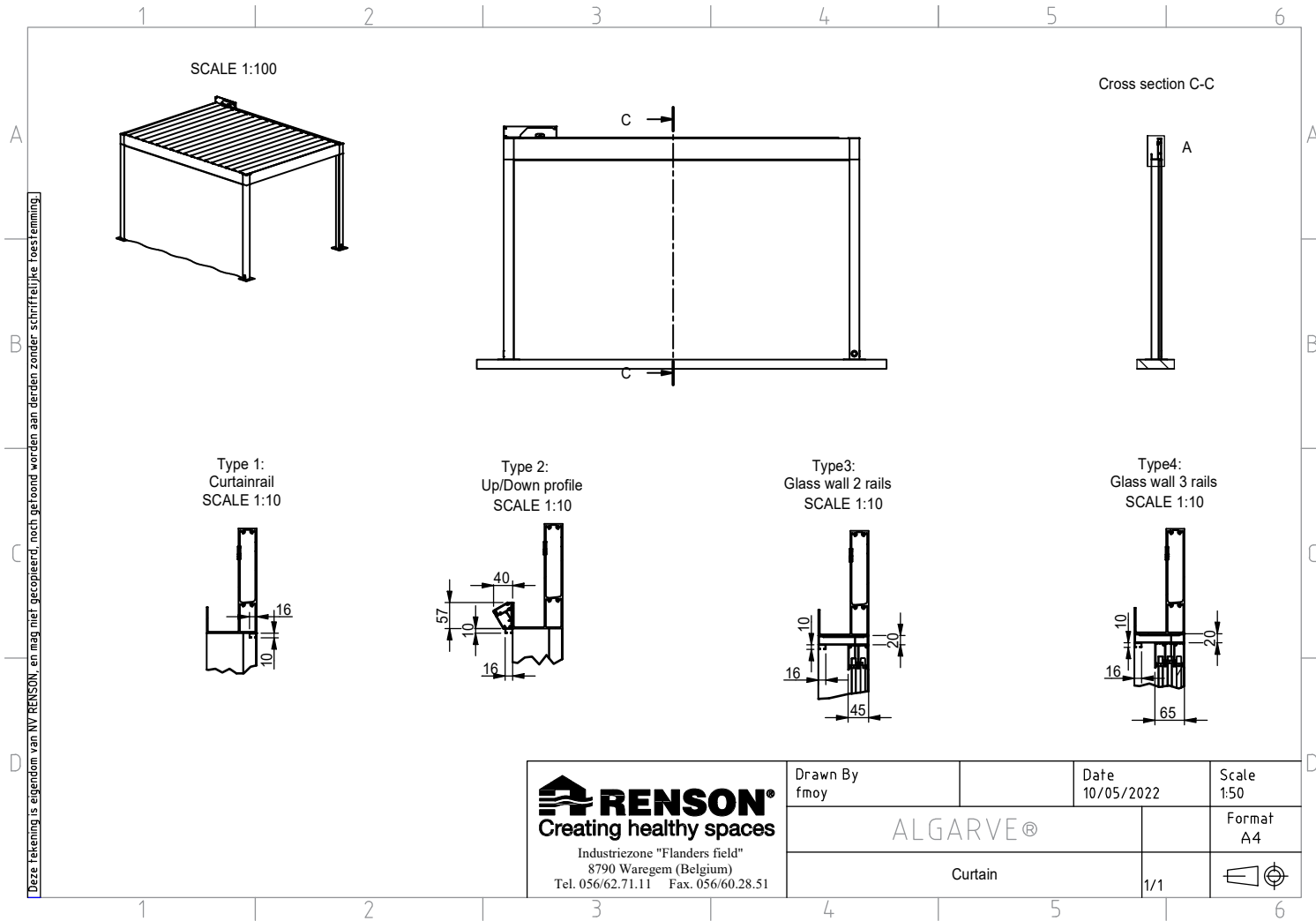

Download this drawing DWG

Download this drawing PDF